



Plastic Safety Systems

CrashGard® Sand Barrel System Product Guide



Distributed by:

“On the Roadway for Safety”®

Version 4.4 11/12

Download full-line
PSS Product Catalog.



General Information

Manual Contents:

This manual provides the information necessary to specify, purchase, and install the CrashGard Sand Barrel System:

General Information:	Page 2-3
Specifications:	Page 4-6
Shipping Configurations:	Page 6
Array Installation Procedure:	Pages 7-8
Insert Installation Instructions:	Page 9
Sand Fill Measurements:	Page 10
Transport Instructions:	Page 11-12
Recommended Array Designs:	Pages 13-14
Mixed Array Recommendation:	Page 15
Contact Us:	Back Cover

CrashGard® Limitations and Warranty

Limitations

The CrashGard® Sand Barrel System meets NCHRP-350 criteria, Test Level 3, for non-redirective, gating crash cushions. It should not be used for any other function.

Impacts that exceed design capabilities may not result in acceptable crash performances as described in NCHRP-350.

Warranty

Plastic Safety Systems, Inc. (PSS):

- Warrants each CrashGard Sand Barrel System is free from manufacturing defects for one (1) year, from date of purchase. (Subject to additional terms and conditions. Please contact PSS for complete warranty.)
- Warrants each CrashGard Sand Barrel System against UV degradation for six (6) years from date of purchase, on a pro-rated, “repair or replace” basis.

CrashGard® is a registered trademark of Plastic Safety, Systems, Inc.

FHWA Issues Acceptance Letters for CrashGard®

In March, 2007, the FHWA issued acceptance letter CC-97 to Plastic Safety Systems, Inc. (PSS) for the CrashGard® Sand Barrel System.

In March, 2009, FHWA issued CC-97A, an amendment to the original letter.

Summary of CC-97 and CC-97A

In CC-97, the FHWA:

- Identifies the CrashGard Sand Barrel System as a non-redirective, gating crash cushion that consists of a barrel, insert, and lid, manufactured from HDPE plastic.
- Acknowledges that PSS conducted and passed full-scale crash tests NCHRP-350, 3-40 through 3-44.
- Confirms that CrashGard meets the criteria of NCHRP-350 Test Level 3 for non-redirective, gating crash cushions.
- States that the CrashGard may be used on the National Highway System.

In CC-97A, the FHWA:

- Accepts the use of CrashGard in “mixed array” configurations.

For our recommendation and advice about placement, please see page 15.



Download PSS CrashGard Manual.

General Information (cont'd)

Description of Sand Barrel:

The Plastic Safety Systems, Inc. (PSS) CrashGard® Sand Barrel System is a non-redirective, gating sand barrel, or crash cushion. Sand barrels are designed to protect fixed objects, whether permanent or temporary. Sand barrels are designed to reduce the likelihood of a vehicle impacting the object.

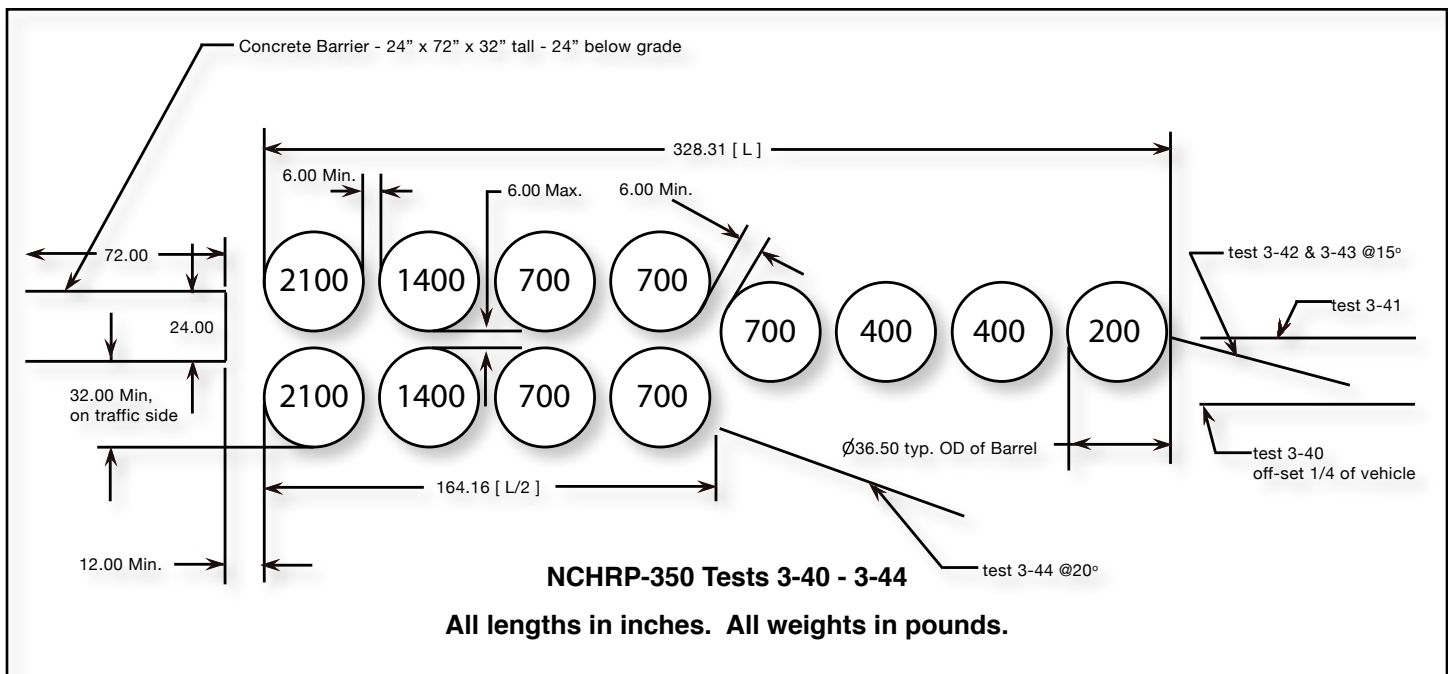

Function of Sand Barrel:

As the *AASHTO Roadside Design Guide* states, sand barrels absorb energy.

AASHTO also states:

- Sand barrels stop the impact vehicle in a short distance and at a controlled rate.
- The controlled rate reduces the potential for injury to the occupants.
- Sand barrels allow the vehicle to pass through the array but they do not redirect the vehicle.

NCHRP-350 Certification:

To ensure effective performance and compliance, PSS tested the CrashGard Sand Barrel System to NCHRP-350 Tests 3-40 through 3-44, at Test Level 3.

CrashGard passed all applicable tests and is certified to (62 miles / 100 kilometers per hour).

The FHWA has issued acceptance letters CC-97 and CC-97A for the CrashGard Sand Barrel System. See previous page for details.

Specifications

Plastic Safety Systems CrashGard®

Plastic Safety Systems, Inc. (PSS) designed the CrashGard® Sand Barrel System for the intended use as a gating, non-redirective crash attenuator.

Description of System:

The CrashGard Sand Barrel consists of 3 components:

Barrel, P/N CC-48:

Overall dimensions: 36.0" diameter, 48.0" height.

Configuration of lower portion: configured in a square profile, which creates lifting shelves at the intermediate section of the barrel.

Design function of lifting shelves: provide support for forklift transport.

Configuration of upper portion: configured in a straight wall. Groove in top of barrel allows for snap-on lid. Barrels will easily nest when empty of contents and with insert and lid removed.

Design function of straight wall: allows for easy application of retro-reflective sheeting, and supports the CrashGard Hoist lift ring used for transport.

Maximum ballast: 2,100 lbs. of sand.
The barrel is marked externally with the following fill marks: 200, 400, 700, 1,400 and 2,100 lbs.



Molding process and material: blow-molded from high molecular, high density polyethylene (HLMI-HDPE) material, which includes UV stabilizer agents. Safety Yellow in color.

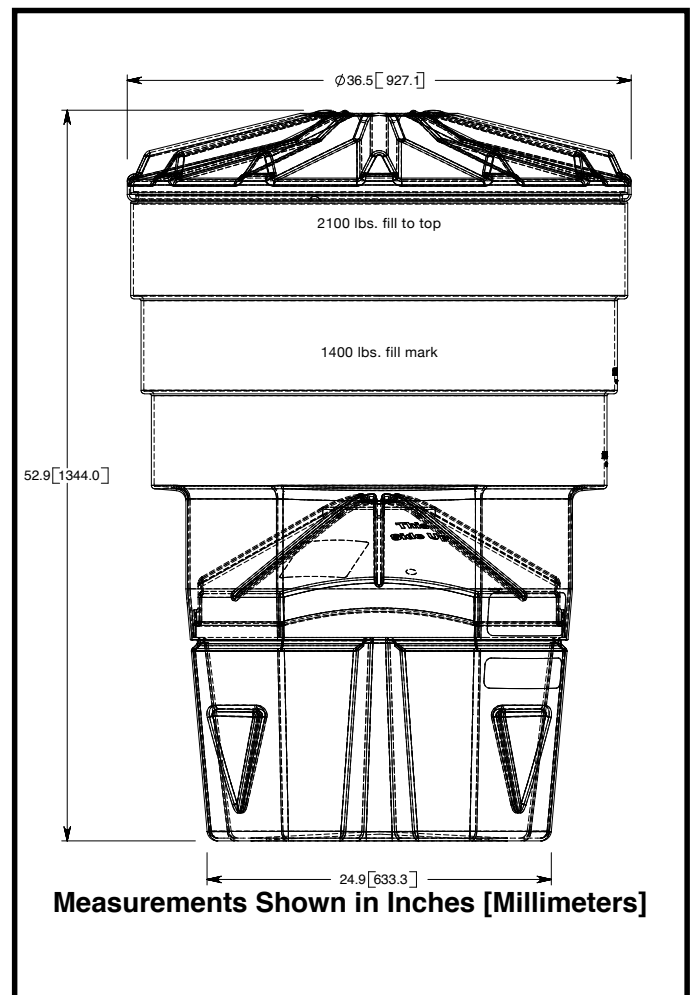

Specifications (cont'd)

Insert, P/N CC-I28:

Overall dimensions: 27.0" square,
10.8" height.

Configuration: conical in shape. Inserts will nest.

Design function: allows for ballast of either 200, 400, or 700 lbs. of sand when installed on the ledge molded into the internal lower portion of the barrel. Install conical side up, as indicated.

Molding process and material: rotationally molded from high density polyethylene (HDPE) material.

Lid, P/N CC-L36:

Overall dimensions: 36.5" diameter,
6.6" height.

Configuration: round in shape. Lids will nest.

Design function: tamper-resistant fit on top of barrel. Reduces vandalism and infiltration of water. Lip of lid snaps into a groove in the top of the barrel.

Molding process and material: blow-molded from high molecular, high density polyethylene (HDMI-HDPE) material, which includes UV stabilizer agents. Black in color.

Performance:

Installers will position the CrashGard Sand Barrel Systems in front of a hazard in an array format.

Each array shall be designed to reduce the rate of deceleration of the impacting vehicle.

Properly designed arrays (as described in pages 13-14) will decelerate the vehicle within the parameters described in NCHRP-350.

Use only sand that meets ASTM C-33, washed concrete sand or equivalent. Use only sand that contains less than 3% moisture. In freezing conditions, add a minimum of 5% rock salt. In all cases, sand must meet state specifications.

Caution: If the sand has been heated recently, make sure it is cool before filling any barrels. Hot sand could distort the barrel, or insert, and cause leaks.

Design and Placement of Arrays:

Design and placement of arrays will adhere to guidelines established in:

American Association of State Highway and Transportation Officials (AASHTO) publication "Roadside Design Guide", 2002 edition.

FHWA Report N5040.16, "Crash Cushions, Selection Criteria and Design", February, 1975.

Tests:

PSS has tested the CrashGard Sand Barrel System to the requirements set forth in NCHRP-350, Test Level 3.

Vist our CrashGard page here.



Specifications (cont'd)

Shipping Configurations

Measurements shown in Inches [Millimeters]

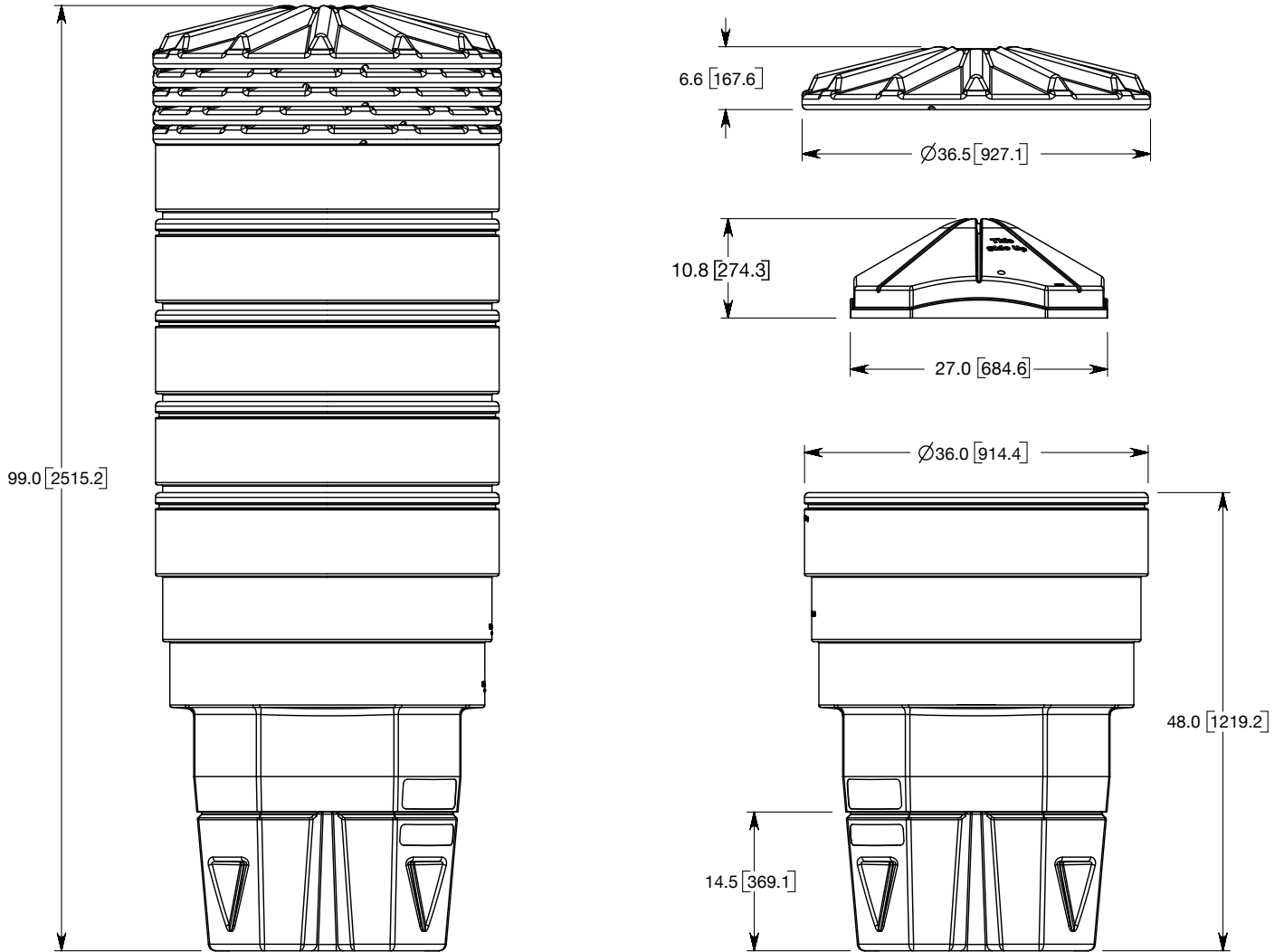

Truckload Shipping Configurations

TL stack consists of:

- 5 CrashGards nested
- 5 lids

Inserts shipped on pallets

The amount of CrashGard barrels per truckload depends upon the amount of inserts required.

Call with your array requirements, and we will calculate shipping configurations for you.

Weights

Lid	7 lbs. [3.18 kg]
Insert	7 lbs. [3.18 kg]
Barrel	38 lbs. [17.24 kg]

Recommended Installation Procedure

Proper installation ensures successful performance.

Review all engineering plans prior to installation for proper design array. Contact Plastic Safety Systems at 800-662-6338 for questions about the CrashGard Sand Barrel System.

Plastic Safety Systems, Inc. recommends the following installation procedure, with dimensions as noted. Note well that state specifications may differ from our recommended dimensions. State specifications always supersede our recommendations.

For example, we recommend a minimum 12" space between the fixed object and the first row of barrels. However, some states specify a minimum of 18". In that case, installers should follow the state specification, and place the barrels at least 18" from the fixed object.

In all installations, installers should adhere to state specifications or drawings.

A) Prepare the Site:

- 1) Implement proper traffic control procedures to protect workers and the driving public:
- 2) Clear the site of any debris or snow.
- 3) Measure the grade of the installation site. The grade should not exceed 5% in either direction. The site requires grading, if over 5%.

B) Set the First Row:

The row of sand barrels, closest to the fixed object, and perpendicular to traffic, is considered the first row. Start the installation at the first row, as the rows should follow a straight line.

- 1) Laterally offset the first row, on the side of traffic, a minimum of 32":
- 2) Allow for a minimum 12" of space between the first row and the fixed object:

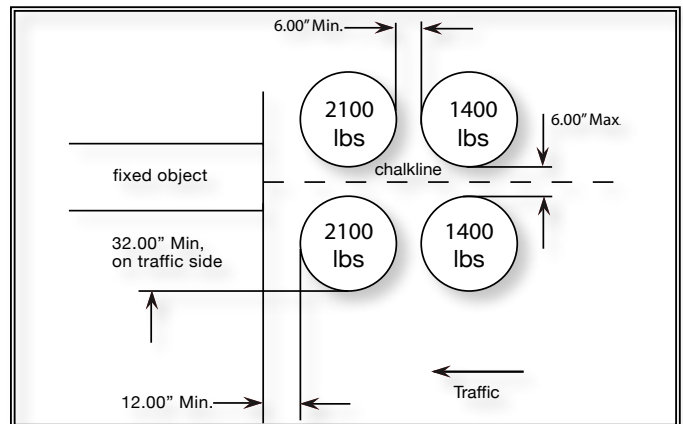

C) Set the rest of the Array:

- 1) Mark the centerline of the array with a chalk line or other marking device. (This works especially well for new installations.)
- 2) Adhering to the centerline, set each barrel in place:
 - a) Allow a **minimum** of 6" between barrels **parallel** to traffic. Measure from the top of the barrel.
 - b) Allow a **maximum** of 6" between barrels **perpendicular** to traffic. Measure from the top of the barrel.



Installation Procedure (cont'd)

D) Fill the Barrels:

- 1) Filling the barrels offsite: follow the directions below, but also make sure to mark the barrels with their respective weights, to avoid misplacement in the array.
- 2) Filling the barrels on site:
 - a) Review the array plans or drawings to determine the appropriate weight for each barrel.
 - b) Install the CrashGard Insert for weights of 200, 400 and 700 lbs.
 - c) Weights of 1,400 and 2,100 lbs. do not require inserts.
- 3) Fill the barrels with the appropriate weight of sand, using the fill level marks on the side of the barrel.

See page 9 of this manual for Insert instructions.

See page 10 of this manual to measure sand fill levels from inside the barrel, if retroreflective sheeting obscures the fill level marks.

- 4) Use only sand that meets ASTM C-33, washed concrete sand or equivalent. Use only sand that contains less than 3% moisture. In freezing conditions, add a minimum of 5% rock salt. In all cases, sand must meet state specifications.

Caution: If the sand has been heated recently, make sure it is cool before filling any barrels. Hot sand could distort the barrel, or insert, and cause leaks.



E) Final Steps:

- 1) Press a lid on each barrel. Check that each has completely snapped into the lid groove on the barrel.
- 2) Clean-up and Inspection.
 - a) Dispose of loose sand properly.
 - b) Remove all tools and equipment from site.
 - c) Inspect all lids for proper installation.
 - d) Review alignment of barrels.
 - e) Compare the array to the specifications for a final check.

DOT Approved Installations:



CrashGard® Insert Instructions

- 1) Determine which barrels in the array require Inserts. Only those barrels with weights of 200, 400 or 700 lbs. require Inserts. Barrels of 1,400 and 2,100 lbs. do not require Inserts.
- 2) Always install the CrashGard Insert with the cone-shaped side face up.



Figure A: Cone-shaped side always faces up.

- 3) Figure A: lean the barrel inward for convenience. Hold the Insert, cone-shaped side face up, with both hands.



Figure B: Match the shapes.

- 4) Figure B: The CrashGard Insert is a square-sided unit. Make sure that the configuration of the Insert matches the configuration of the barrel shelf upon which it rests. Slowly drop the Insert into position.

- 5) Figure C: once properly aligned, press-fit the Insert into the barrel. There should be no rocking or sliding; the Insert should fit snugly.



Figure C: Press-fit the insert.

- 6) Figure D: fill the barrel with sand.



Figure D: Ready for Sand.

Refer to the previous page for filling instructions. Refer to the next page for measurements, if needed.

CrashGard® Sand Fill Measurements

Dimensions in Inches [Millimeters]

To determine sand fill levels from the inside of the barrel, use the measurements listed below. Measure from the TOP of the barrel to determine the appropriate fill level.

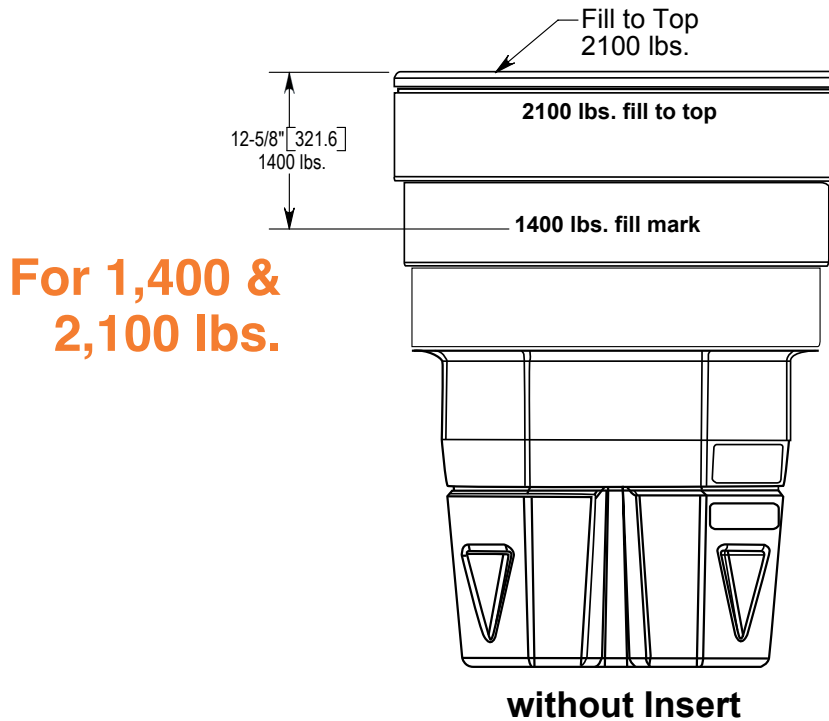

**For 200, 400
& 700 lbs.**

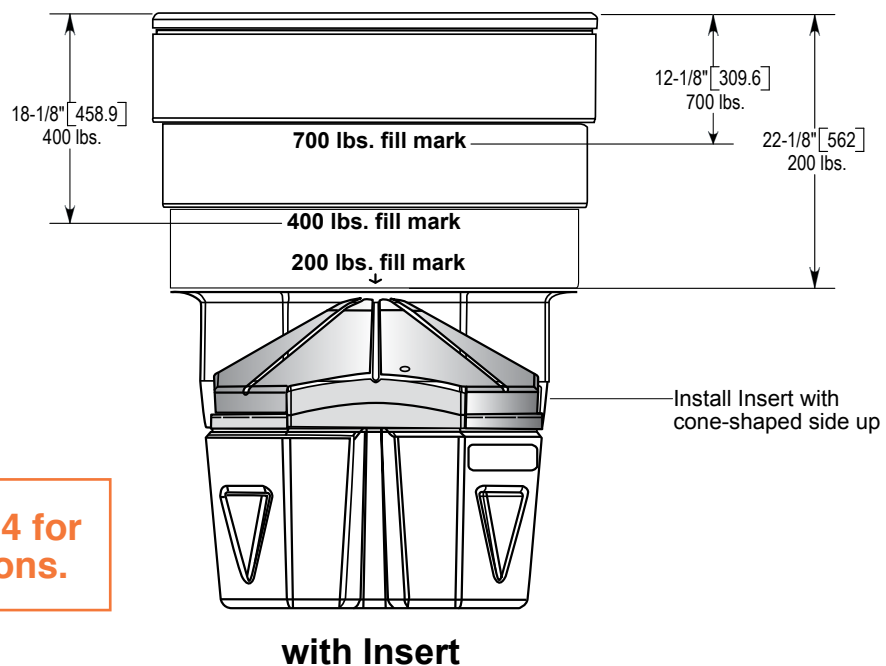

See page 8, Item 4 for
sand specifications.

Forklift Transport Instructions

We designed the CrashGard Sand Barrel System for both safe and easy transport using a forklift truck or our CrashGard Hoist.

To accommodate forklift trucks, we designed four flat sides, located just below the bottom round tier, at the 200 lb. fill level. We also designed that bottom tier to act as a “shelf” for the forklift blades.

Forklift Instructions:

- 1) Caution: never stand or walk under a sand barrel during transport.
- 2) Measure the distance between forklift blades, from inside to inside. That distance should not exceed 28”.
- 3) Figure A: align the blade with the flat sides of the barrel.

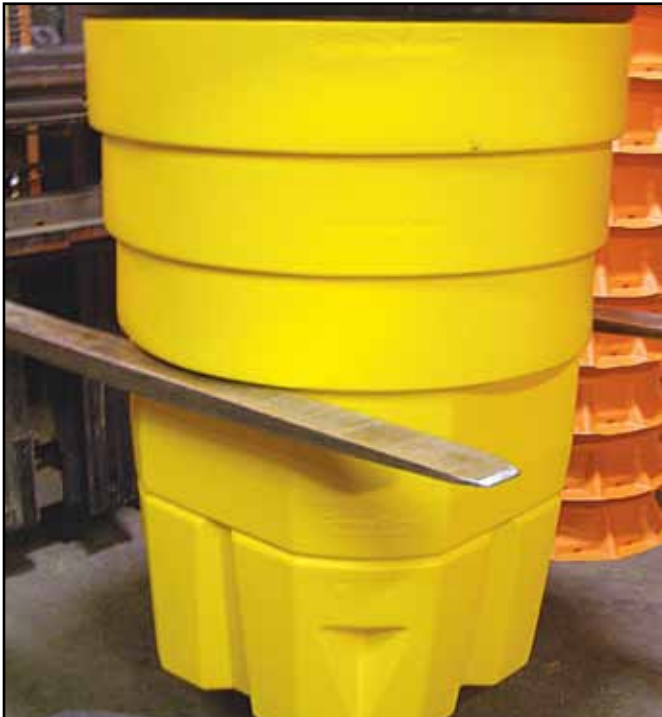

Figure A

- 4) Figure B: if the barrel contains any significant weight, use the center of the blades for balance.



Figure B

- 5) Figure C: Many forklift blades become looser after years of use. To ensure the blades maintain consistent distance, we suggest using a chain binder, or similar type binding equipment.



Figure C

CrashGard® Hoist Transport Instructions

We designed and manufactured the CrashGard Hoist for the safe, easy and efficient transport of CrashGard sand barrels. With CrashGard Hoist, loading or unloading a truck is at most a two-person operation, and often a one-person operation.

CrashGard Hoist operates in a scissor-like mode, to engage and disengage as necessary, and uses the CrashGard barrel itself to do so.

CrashGard Hoist Instructions:

- 1) Caution: never stand or walk under a sand barrel during transport.
- 2) Figure A: using a boom, simply hook the Hoist's lifting ring. Raise the Hoist.



Figure A

- 3) Figures B and C: align the Hoist over a CrashGard barrel, and slowly lower it. The lid of the barrel will open the Hoist.



Figure B



Figure C

- 4) Figures D and E: continue to lower the Hoist until it is fully open and rests upon the barrel top.



Figure D



Figure E

- 5) Figure F: raise the Hoist. The tension on the steel cables will cause the Hoist to clamp tightly, directly underneath the middle round tier.



Figure F



Figure G

Figure G: once engaged, continue to raise the Hoist, and carry it to its destination. Place the barrel where appropriate.

To disengage the Hoist:

- 1) Lower the Hoist to full rest on the lid of the barrel. The Hoist will open.
- 2) While the Hoist is in the open position, simply slide it off either side of the barrel.
- 3) Once off, raise the Hoist clear of the barrel to pick up another.

Note: Some lifting devices made by other barrel manufacturers are adjustable by size. If using a device with settings to transport CrashGard, we recommend setting the device to "large".

Recommended Arrays

Design Velocity 70 mph
19 barrels/array

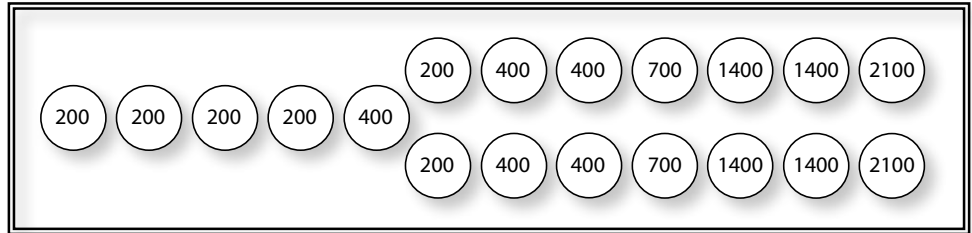

Design Velocity 65 mph
17 barrels/array

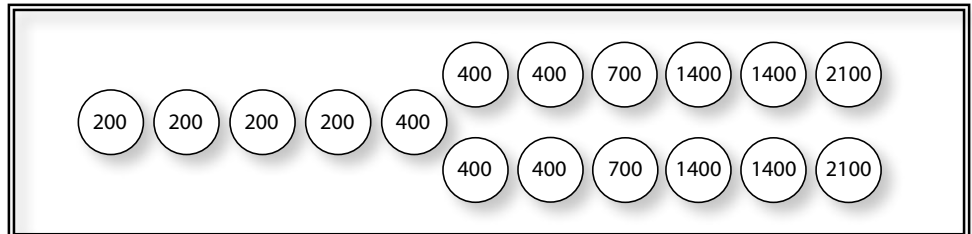

Design Velocity 60 mph
14 barrels/array

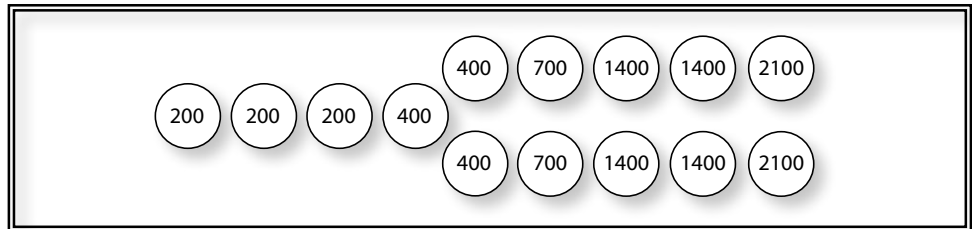

Design Velocity 55 mph
12 barrels/array

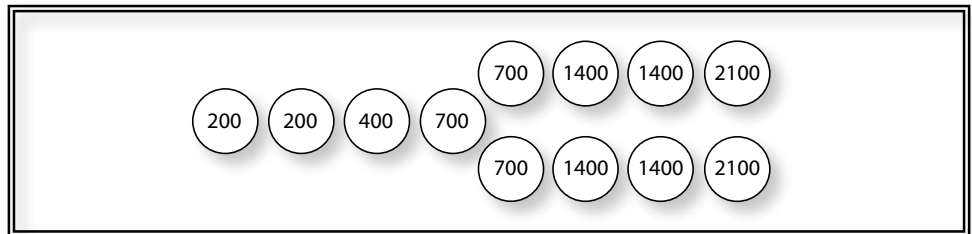

Design Velocity 50 mph
10 barrels/array

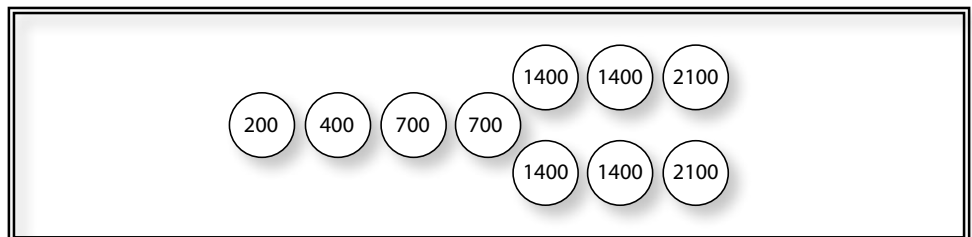

Design Velocity 45 mph
9 barrels/array

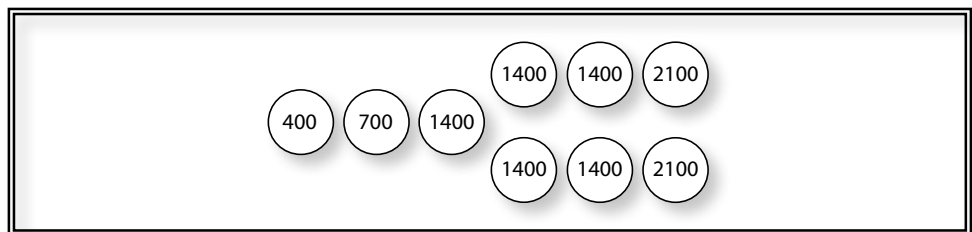

Weights listed are in pounds of sand. For metric weights and speeds, see the conversion chart on page 14. PSS recommends the above arrays for the designated speeds, as noted. When combining CrashGard along with sand barrels from other manufacturers, (commonly referred to as mixed arrays) PSS recommends the installer follow the manufacturers' recommendation, design or plan that utilizes the highest number of barrels. See page 15 for further instructions.

Recommended Arrays

Design Velocity 40 mph
8 barrels/array

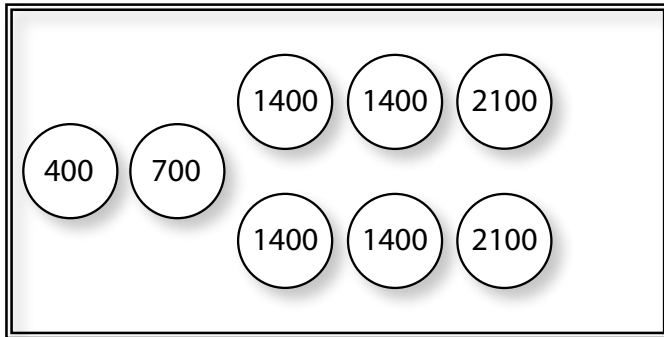

Design Velocity 35 mph
7 barrels/array

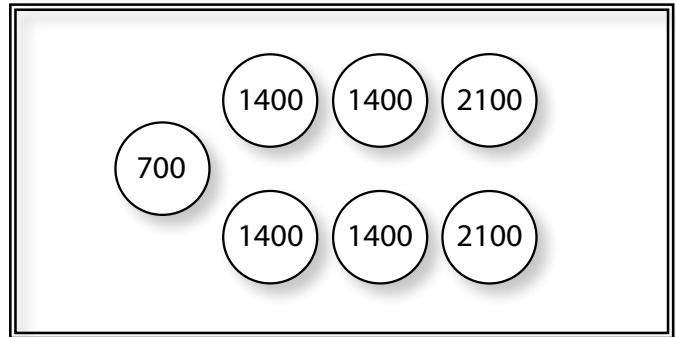

Design Velocity 30 mph
7 barrels/array

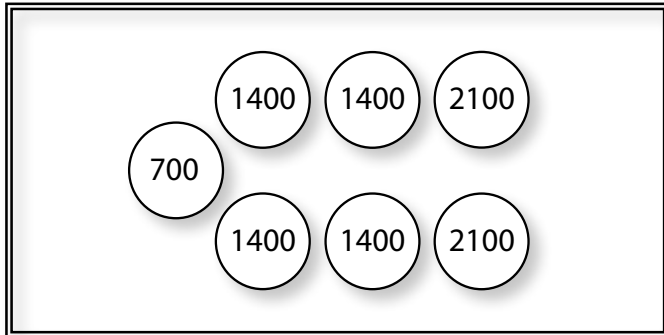

Design Velocity 25 mph
6 barrels/array

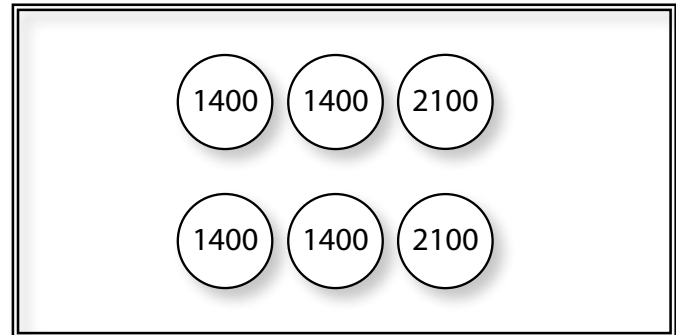

Metric Conversion Table

Speed MPH	Kilometers (km)	Weight	
		Lbs.	Kilograms
25	40.2	200	90.7
30	48.3	400	181.4
35	56.3	700	317.5
40	64.4	1,400	635.0
45	72.4	2,100	952.5
50	80.5		
55	88.5		
60	96.6		
65	104.6		
70	112.6		

Weights listed are in pounds of sand. For metric weights and speeds, see the conversion chart above. PSS recommends the above arrays for the designated speeds, as noted. When combining CrashGard along with sand barrels from other manufacturers, (commonly referred to as mixed arrays) PSS recommends the installer follow the manufacturers' recommendation, design or plan that utilizes the highest number of barrels. See page 15 for further instructions.

Mixed Array Recommendation

FHWA issued Acceptance Letter CC-97A, an amendment to the original letter, CC-97. In CC-97A, FHWA accepts the use of our CrashGard Sand Barrel in “mixed arrays”.

A mixed array is defined as an array that contains barrels from different manufacturers. A mixed array usually evolves as portions of the original array are destroyed in crashes over time. The installers may replace the destroyed barrels with new ones from another manufacturer, thus creating the mixed array.

However, we, the manufacturer, advise and recommend that:

- Installers should ALWAYS place CrashGard BEHIND shorter barrels.
- Installers should NEVER place CrashGard IN FRONT OF shorter barrels.

Installation of a mixed array against this advice and instruction may cause the CrashGard barrels to not perform as designed or intended.

Installers may place CrashGard in front of, next to, or behind other manufacturers’ barrels, when those barrels are the same height as CrashGard.

CrashGard is completely interchangeable with other manufacturers’ barrels of the same height.

Please call our technical support staff for more information: 800-662-6338.

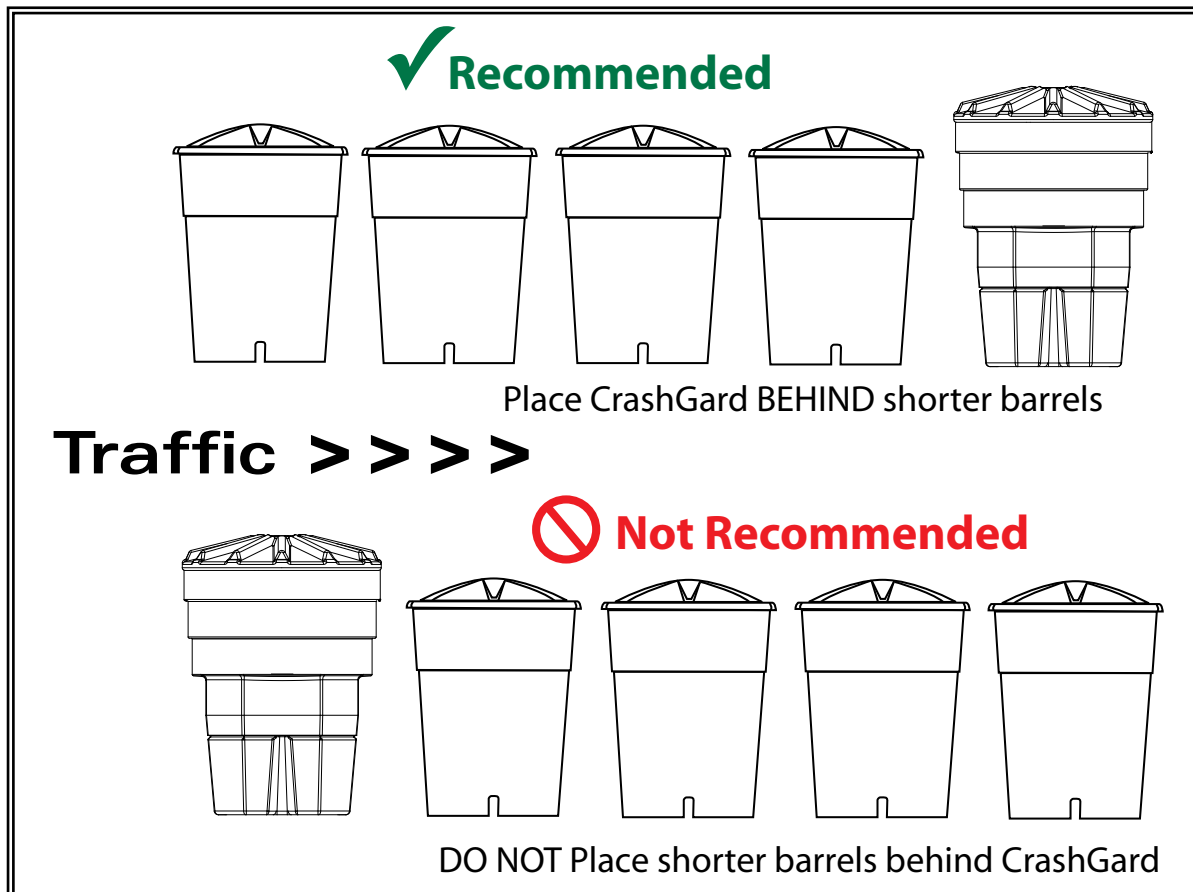

PSS Sales Representatives

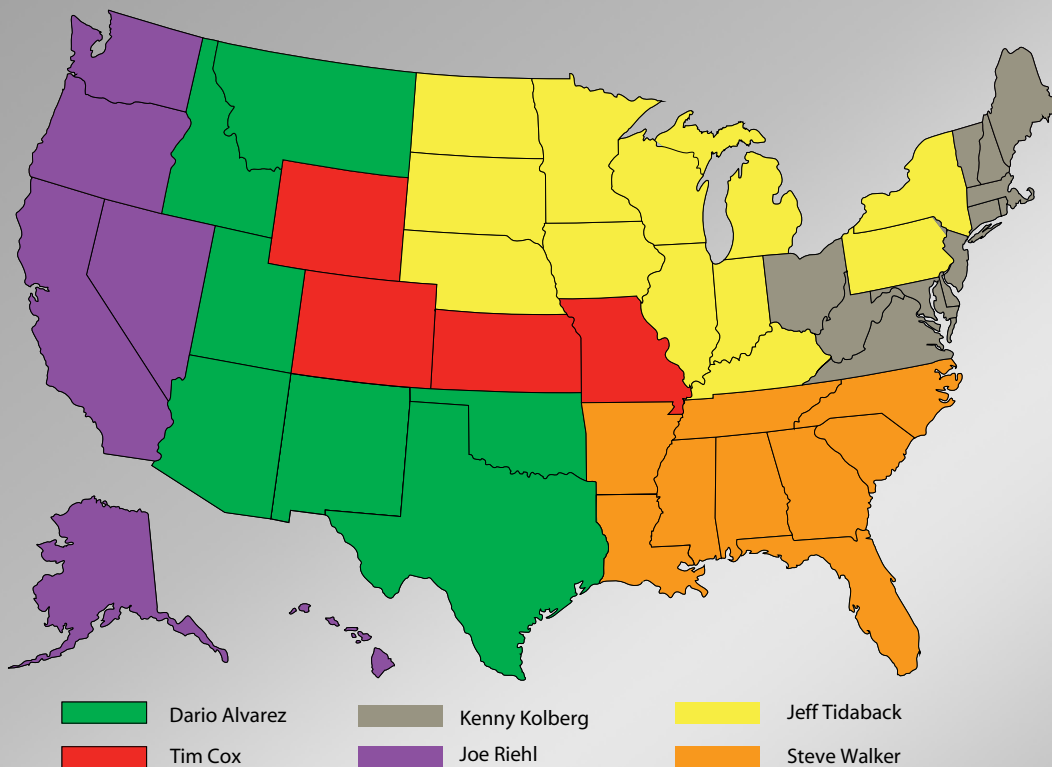

Tim Cox – National & Int'l Sales Manager
 Plastic Safety Systems
 Blue Springs, Missouri
 Cell: 216-244-3207
 Email: tjcox@plasticsafety.com

Joe Riehl – Representative
 Capitol Barricade, Inc.
 Sacramento, California
 Cell: 916-719-5125
 Email: jariehl@aol.com

Dario Alvarez – Regional Sales Manager
 Plastic Safety Systems
 Round Rock, Texas
 Cell: 216-409-6032
 Email: dealvarez@plasticsafety.com

Jeff Tidaback – Regional Sales Manager
 Plastic Safety Systems
 Arlington Hts, Illinois
 Cell: 216-409-6842
 Email: jatidaback@plasticsafety.com

Kenny Kolberg – Regional Sales Manager
 Plastic Safety Systems
 Perry, Ohio
 Cell: 216-280-5566
 Email: kakolberg@plasticsafety.com

Steve Walker – Regional Sales Manager
 Plastic Safety Systems
 Acworth, Georgia
 Cell: 216-409-6468
 Email: smwalker@plasticsafety.com



CUSTOMER & TECHNICAL SUPPORT

Plastic Safety Systems, Inc.
 2444 Baldwin Rd. Cleveland OH 44104
 800-662-6338
www.plasticsafety.com



Contact sales
 staff online.